

NU-TREND HOMES

Pre-owned School Unit



\$75,000 @ less than \$35 per sq. ft.

(Includes Delivery within a 200 mile radius)

Available Now!

*** Buyer Responsible for All Permits, Utility Hookups & Site**

- 2 ADA Restrooms
- 6" Walls, All Drywall
- A/C and Furnace Included
- Vinyl Siding / Shingled Roof

* Floorplan not Exact / Call For Additional Specs

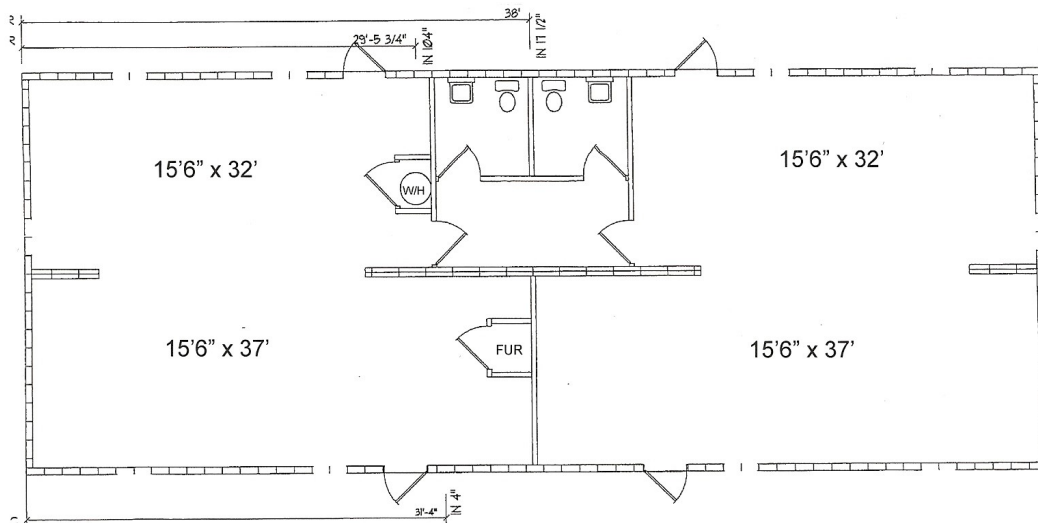

6363 Grover Street • Omaha, NE 68106 • 402-733-8900 • www.nutrendomaha.com
Mon - Fri 8am to 5pm • Closed Saturday and Sunday • After Hours By Appointment